

Rolling contact bearings

6.1 Types of rolling contact bearings

Friction between moving parts can not be eliminated entirely, but often it is reduced most effectively by using some form of rolling bearings. There are many types of rolling contact bearings which suit different applications. The most common types are, See fig.(6.1):

1. Ball bearings
 - 1.1. Single row ball bearing
 - 1.2. Double row ball bearing
 - 1.3. Self alignment ball bearing
 - 1.4. Angular contact ball bearing
 - 1.5. Thrust ball bearing
2. Roller contact bearings
 - 2.1. Taper roller bearing
 - 2.2. Straight roller bearing
 - 2.3. Conical roller bearing
 - 2.4. Concave roller bearing
 - 2.5. Thrust roller bearing
 - 2.6. Needle bearings

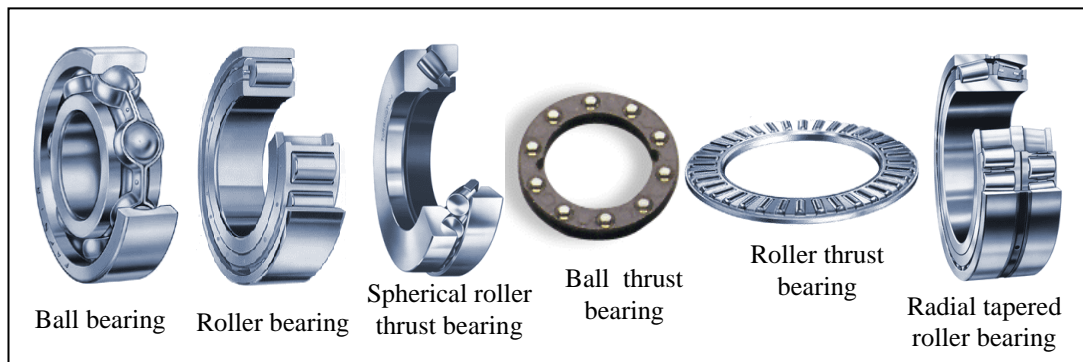

Fig. (6.1) Cut view of different types of rolling contact bearings

The loading on roller contact bearings can be classified into three groups:

1. Solely radial loading
2. Solely axial loading
3. Combined radial and axial loading

Ball and roller bearings are manufactured in several series, the most popular ones are shown in fig (6.2). Within each of these series is a wide range of different bearing sizes. Heavy series bearings have the greater load carrying capacity but extra light series bearings run at higher speeds, assuming the bearings have the same bore diameter and of similar internal construction.

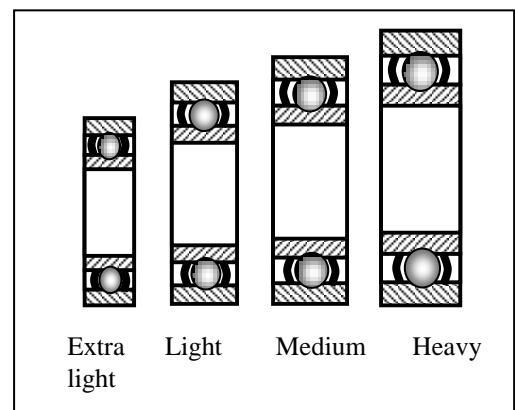

Fig. (6.2) Series of ball

6.2 Standardisation of ball bearings:

Through the effort of the society of Automotive Engineers (SAE) the manufacturers of radial ball bearings have adopted the international standard dimensions, according to which the light series is designated by the number 200, the medium by 300 and the heavy by 400. The last two digits of a standard bearing number designate the bore diameter which comes in multiple of 5 mm, see fig. (6.3)

6.3 Main parts of a typical ball bearing

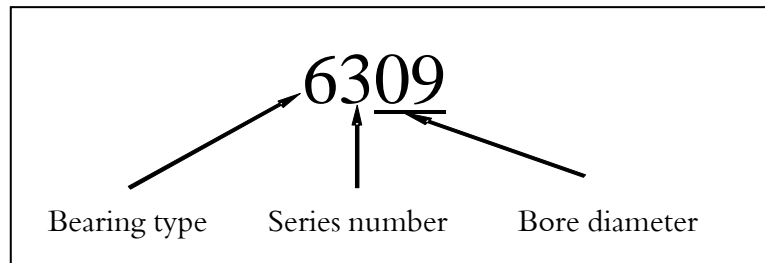

Fig. (6.3) Bearing designation number

The main parts of a typical ball bearing are :

- 1.The outer ring, (outer race).
- 2.The inner ring ,(inner race).
- 3.The rolling elements, (ball).
- 4.The ball retainer (the cage)

See fig. (6.4)

6.4 Selection of ball bearings:

In selecting a ball bearing from trade catalogue for specific installation three main points must be considered:

1. The bearing must be of the series best suited to the installation, in regard to both capacity and dimensions.
2. The type of bearing selected, radial, thrust or combined must be suitable for the type of imposed load.
3. The size of the bearing must be such as to give the required length of service with sufficient assurance.

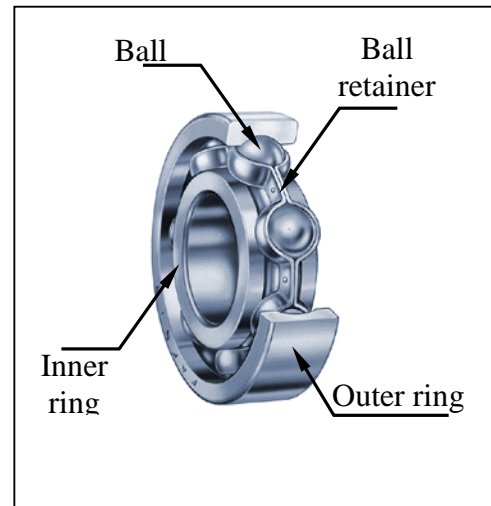

Fig. (6.4) Main parts of a typical ball bearing

In the majority of applications ball bearings have to resist some combination of radial and thrust loads. The bearing rating is always referred to a radial load. There for the combined load must be reduced to an equivalent radial load. Various catalogues give different methods of reduction. In general the equivalent load F_e may be computed by the equation:

$$F_e = XF_r + YF_a \tag{6.1}$$

Where,

F_e : equivalent radial load

F_r : actual radial load

F_a : actual axial load

X and Y are coefficients which depends on the ratio F_a/F_r . For most bearings The values given in table (6.1) are suitable.

Table (6.1) Values of X and Y

Type of bearing	Y	X
<i>Deep groove</i>	1.5	1
<i>Angular contact</i>	1	0.5
<i>Self aligning</i>	2.5	0.5

Experiments have shown that the life of a ball bearing is a function of the load it carries. It also showed that the service life of a ball bearing is inversely proportional to the value of the load it carries raised to power 3. In other words it can be expressed by the equation

$$L_n = \left(\frac{C}{F_e} \right)^3 \tag{6.2}$$

Where,

C: dynamic specific capacity of bearing.

L_n : Life of bearing in millions of revolution.

F_e : Equivalent load

Table (6.4) shows the dynamic specific capacity for SKF bearings. SKF engineers introduced speed factor and life factor which can be taken from fig.(6.5) and fig. (6.6) respectively. The required dynamic capacity can be obtained from the equation:

$$F_c \geq \frac{f_s F_e f_h}{f_n} \tag{6.3}$$

Where

f_s : safety factor

f_n : speed factor

f_h : life factor

F_c : dynamic capacity of the bearing

Bearing life

	Class of machine	Life in working hours
1	Instruments and apparatus that are used only seldom. Demonstration apparatus, mechanisms for operating sliding doors	
2	Aircraft engines	1000 - 2000

3	Machines used for short periods or intermittently and whose brake down would not have serious consequences; hand tools, lifting tackles in workshops, hand operated machines, generally agricultural machines, cranes in erecting shops, domestic machines	4000 - 8000
4	Machines working intermittently and where breakdown would have serious consequences. Auxiliary machines in power stations, conveyor plant for flow production, lifts cranes for piece goods; machine tools used infrequently	8000 - 12000
5	Machine for use 8 hours per day and fully utilized: stationary electric motors, general purpose gear units.	12000 - 20000
6	Machine for use 8 hours per day and fully utilized: machines for engineering industry generally: cranes for bulk goods, ventilating fans, countershafts	20000 - 30000
7	Machines for continuous use 24 hours per day: Separators, compressors, pumps, mine hoist, stationary electric machines, machines in continuous operations on board naval ships	40000 - 60000
8	Machines required to work with high degree of reliability 24 hours per day: pulp and paper machinery; public power plants, mine pumps, pumps in water works, machinery in continuous operation on board merchant ships	100000 - 200000

6.5 Installation of ball bearings:

In the installation of ball bearings the following points must be considered separately:

1. The shaft must be designed to take the inner ring (race), see fig. (6.7)
2. A suitable mounting must be designed for the outer ring (race).
3. Lubrication must be provided for the bearing
4. Methods of sealing the lubricant and preventing penetration of foreign matter must be provided.

Example 1

Determine the load capacity of a single row deep-groove SKF bearing – SKF 10, medium series, that must run 2000 hours at 700 rpm.

Solution:

From table (6.4) $C = 10400 \text{ lb}$

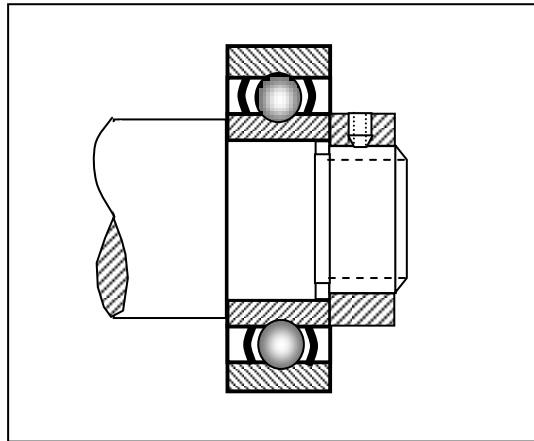

Fig. (6.7) A method of fastening ball bearing to a shaft

From fig.(6.5) $f_n = 0.36$

From fig.(6.6) $f_h = 1.58$

Hence from equation (6.3) $F_c \geq \frac{f_s F_e f_h}{f_n}$

$$F_e = \frac{F_c f_n}{f_s f_h}$$

Take safety factor $f_s = 1$

$$F_e = \frac{10400 \times 0.36}{1 \times 1.58}$$

$$F_e = \underline{2370}$$

Example 2

A shaft is supported by two bearings . One of the bearings carries a radial load of 200 lb and an axial load of 500 lb with minor shocks. The shaft runs at

Exercises

1. The main shaft in a reduction gear-box is shown in fig.(1). The shaft is to be supported by two deep groove ball bearing at A and D. In addition to the radial loads the shaft carries an axial load of 175 lb. Determine the bearings loads and select suitable single row deep groove bearings if the shaft rotates at 1200 rpm and operates 7 hours per day, five days a week for five years. Take factor of safety = 1.5. The maximum diameter of the shaft at both ends should not exceed 30 mm

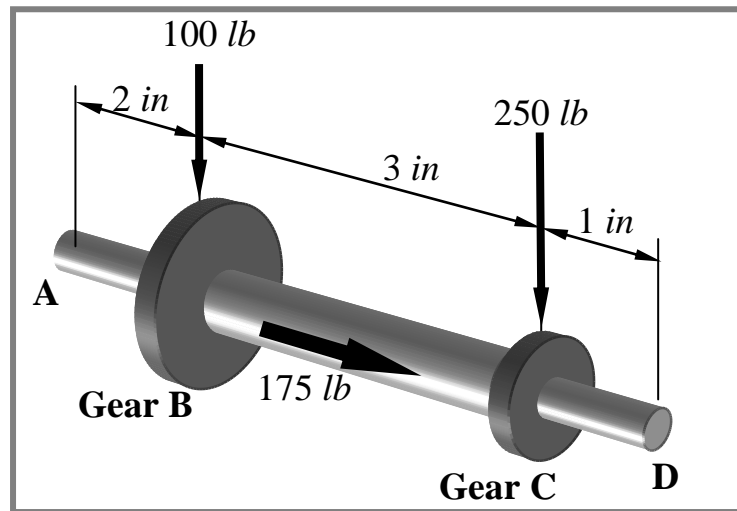
**Fig.(1)**

2. Select suitable deep groove ball bearings for the spindle of a woodworking machine revolving at 1200 rpm. One bearing is subjected to a radial load of 600 lb and the other carries a radial load of 820 lb. An axial load of 310 lb is acting along the machine spindle. The machine is to be used 8 hours per day and 5 days a week, and a service life of 10 years is desired. The diameter of the spindle is 2 in. and can be turned down slightly.
3. A reduction gear-box is shown in fig.(2). It consists of two helical gears fixed to shafts X and Y. Shaft X is supported by two single row deep groove ball bearings. On shaft X, the bearings and the helical gear are located as follows:
 - The distance between the centre of pulley and centre of bearing A = 35 mm,
 - The distance between the centre of pulley and centre of helical gear = 90 mm,
 - The distance between the centre of pulley and centre of bearing B = 135 mm.

The helical gear exerts the following loads on shaft X:

Radial load = 100 lb

Tangential load = 150 lb

Axial load = 50 lb

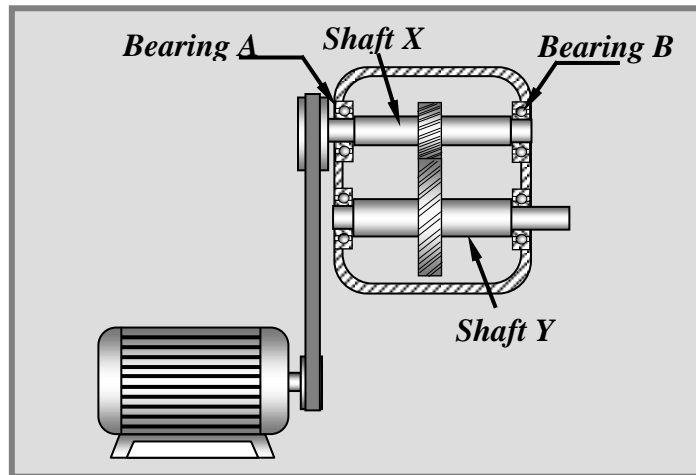

Fig.(2)

4. Determine the bearings loads and select suitable single row deep groove bearings if the shaft rotates at 1500 rpm and operates 8 hours per day, seven days a week for five years. Take factor of safety = 1.5
5. A shaft supported by two ball bearings: A and B is shown in fig. (3). The shaft carries two pulleys with radial loads 250 lb and 600 lb. An axial load of 300 lb is acting along the shaft in the direction indicated by the arrow. The shaft runs at speed of 1500 rpm for 8 hours per day and 5 days a week, and a

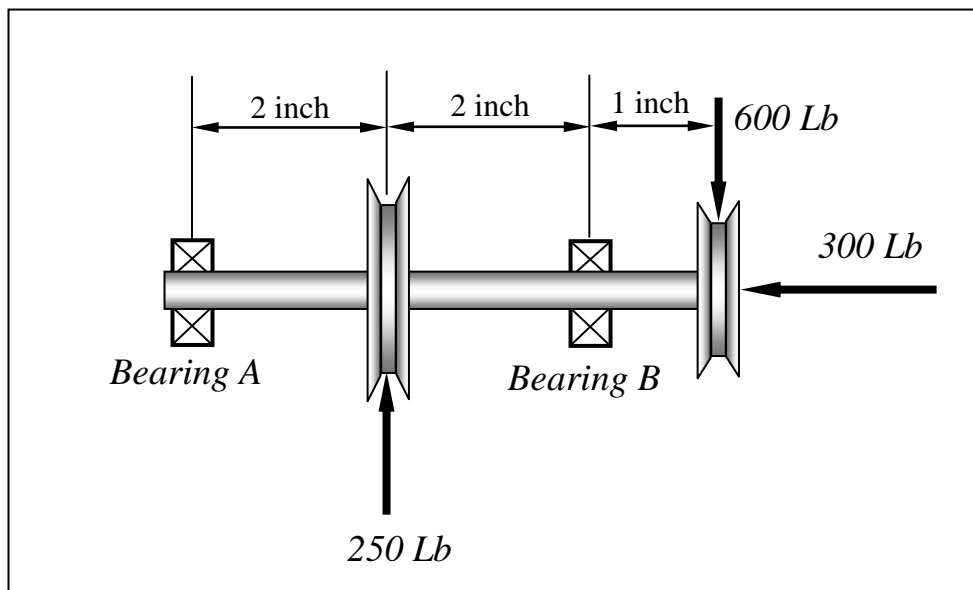

Fig. (3)

service life of 10 years is desired. The minimum diameter of the shaft is not less than 1 inch. Select suitable ball bearings.

6. Determine the load capacity of a single row deep-groove SKF bearing – SKF 15, heavy series, that must run 3000 hours at 600 rpm. Fig. (4) shows a shaft supported by two ball bearings and runs at 1000 rpm. A radial and axial loads act on the shaft with minor shocks. If the shafts operate for 16 hours per day and total service life required is 3 years select suitable bearings for the shaft. The minimum diameter off both ends of the shaft is not less than 9 mm.
7. Select suitable ball bearings for the spindle of a woodworking machine revolving at 1200 rpm. One bearing is subjected to a radial load of 600 lb

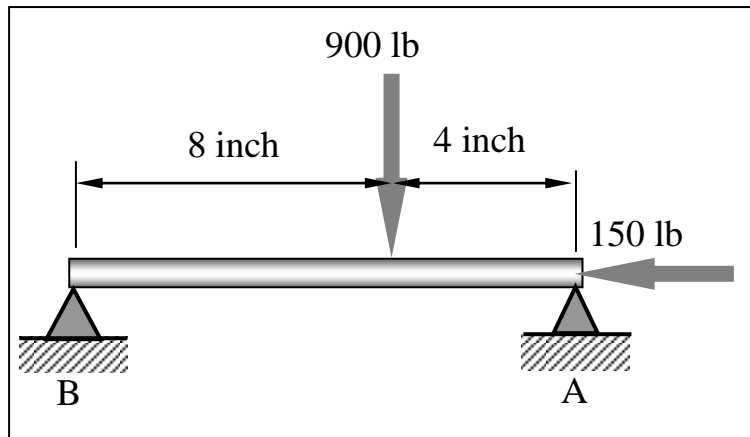

Fig. (4)

and a thrust load of 450 lb; the other carries only a radial load of 650 lb. The machine is to be used 8 hour per day and 5 days a week, and a service life of 10 years is desired. The diameter of the spindle is 2 in. and can be turned down slightly.

8. A ball bearing is to be used on a drill press operating at 3000 rpm with a 250 lb maximum thrust load and 500 lb radial load. The press will be operated five 8-hour days a week but will be idle 20% of the time. Determine the type and size of the bearing (a) if it should last 1 year. (b) if it should last 2 years.
9. Determine the radial capacity of an SKF 6211-Z bearing running at 500 rpm and carrying an axial load of 500 lb, for 2 years of continuous service.
10. A shaft is supported by two bearings 16 in apart and carries a bevel gear of 7.75 in pitch diameter. The gear is at 6 in from one end of the shaft. The gear produces a radial load of 2150 lb and a thrust load of 625 lb when rotating at 525 rpm. Determine :
- The shaft diameter if the shaft is made of SAE1045 steel and
 - The proper type and size of ball bearings to be used on each end of the shaft. The desired life is 2 years at 50 hour/week.

Table (6.2) Safety factors for MRB ball bearings

Load conditions	Safety factor, life of 5 to 10 years			Safety factor, life of 10 to 20 years
	Intermittent	10 hours per day	Continuous	Continuous
Steady load	0.5 ----- 1	1.5	2	3
Light shock	1 ----- 2	2.5	3	4
Moderate shock	2 ----- 3	3.5	4	5
Severe shock	3----- 4	4.5	5	6

Table (6.1) Values of X and Y

Type of bearing	Y	X
<i>Deep groove</i>	1.5	1
<i>Angular contact</i>	1	0.5
<i>Self aligning</i>	2.5	0.5

Table (6.3) Over-all dimensions of radial ball bearings

SAE Bearing Number	Bore of inner race (d)		Outside diameter D mm			Width B (mm)		
	mm	in	200 series	300 series	400 series	200 series	300 series	400 series
00	10	0.3937	30	35	9	11
01	12	0.4724	32	37	10	12
02	15	0.5906	35	42	11	13
03	17	0.6693	40	47	62	12	14	17
04	20	0.7874	47	52	72	14	15	19
05	25	0.9843	52	62	80	15	17	21
06	30	1.1811	62	72	90	16	19	23
07	35	1.3780	72	80	100	17	21	25
08	40	1.5748	80	90	110	18	23	27
09	45	1.7717	85	100	120	19	25	29
10	50	1.9685	90	110	130	20	27	31
11	55	2.1654	100	120	140	21	29	33
12	60	2.3622	110	130	150	22	31	35
13	65	2.5591	120	140	160	23	33	37
14	70	2.7559	125	150	180	24	35	42
15	75	2.9528	130	160	190	25	37	45
16	80	3.1496	140	170	200	26	39	48
17	85	3.3465	150	180	210	28	41	52
18	90	3.5433	160	190	225	30	43	54
19	95	3.7402	170	200	32	45
20	100	3.9370	180	215	34	47
21	105	4.1339	190	225	36	49
22	110	4.3307	200	240	38	50

Table (6.4) Specific dynamic capacity of SKF ball bearings, in Pounds

SAE Number	Double-row self-aligning			Single-row deep-groove			Double-row deep-groove			Single-row Angular-contact		
	200	300	400	200	300	400	200	300	400	200	300	400
00	865	750	1460	1220
01	915	1500	1140	1800	1860
02	1250	1630	1250	1960	2040
03	1400	2120	1600	2360	2600	3800
04	1830	2240	2160	2750	3550	4500	2700
05	2240	3250	2320	3650	6300	3800	6000	2280	3800	6200
06	3100	4050	6100	3250	4800	7500	5300	7800	13400	3200	4800	7350
07	3350	4800	7050	4300	5700	9500	7100	9300	14000	4250	5700	9300
08	4250	6100	8050	4900	6950	11000	8000	11200	17600	5100	6950	10600
09	4750	7650	10400	5500	9000	13200	9000	14600	22000	5700	9000	12900
10	5100	8650	12000	5850	10400	14600	9650	17000	27500	6000	10400	14300
11	6200	10400	12700	7350	12000	17300	11800	19300	27500	7350	12000	16600
12	7100	12000	15300	8800	13700	19000	14300	22000	30500	8800	13700	18300
13	7650	12700	16300	9650	15300	20800	15600	25000	10000	15300	20000
14	8500	15300	20000	10400	17000	26000	17000	27500	11000	17000	25500
15	9300	16300	22800	11000	18600	28000	18000	30500	11400	19000	27000
16	9800	18000	25500	12200	20800	19600	33500	12700	20800
17	11800	20000	27500	13700	22400	20400	33500	14300	22800
18	12900	22800	31000	15600	24500	23200	35500	16600	24500
19	25500	17600	26500	28500	17600	26500
20	16300	27500	19600	30500	32000	19600	32500
21	31000	21600	32500	34500
22	20400	33500	24000	37500	24000	39000
24	27500
26	31000	48000
28	33500
30	39000	58500
32	41500